

Post Processor Request Form

Due to the complexity and wide variety of machines and controls we ask that you complete the relevant areas of the following forms when requesting a post processor for a given machine. Completion of the relevant forms will allow us to keep the turn around time of your request to a minimum. Often times, post assistance is delayed due to a lack of information and/or specifications needed to complete the process. Other times we are overwhelmed with extraneous data which takes large amounts of time to sort through only to find that the information really needed was not supplied.

To help us provide the best service possible, please complete only those pages that pertain to your given machine type. **Each post request should include complete "G-code" and "M-code" lists and canned cycle information (if applicable). Sample NC code files with examples of start of file, tool changes, coolant on/off, cutter compensation, arcs and canned cycles are also required.** We will contact you if more information is required to process your request.

Adobe Standard/Pro users - Email completed document to info@multiaxis.com

Adobe Reader users - Print and fax completed document:
Attention: Post Department
Fax Number: (253) 333-0127

Company Information:

Sim Number (if end user): _____ **Mastercam Version:** _____

Company Name: _____

Contact Name: _____ **Title:** _____

Address: _____

Phone: ___ - ___ - ___ **Fax:** ___ - ___ - ___

Email: _____

Website (optional): _____

5 Axis Machine Specific

Machine Type:

- + **Table/Table** - Both rotary axis are located on the machine base and the spindle remains constant.
- + **Head/Table** - One axis tilts the spindle while the other rotary axis is located on the machine base.
- + **Head/Head** - Both rotary axis are located in the machine head and tilt the spindle.

Rotary Type:

- + **Standard:** Rotary axis are perpendicular
- + **Nutator:** Rotary axis are **not** perpendicular

What is the axis layout of the machine?

Please provide a diagram of the machine with clear labeling of each axis and its limits
Diagram must include signed axis movement (i.e. X+, Y+, Z+, A+, B+)

Examples...

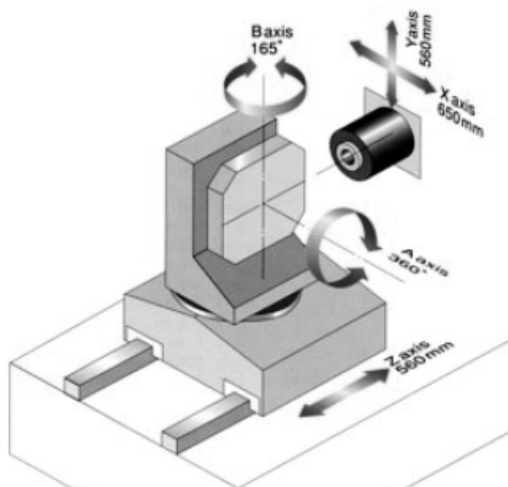

(Diagram is nice but is missing signed movement direction...)

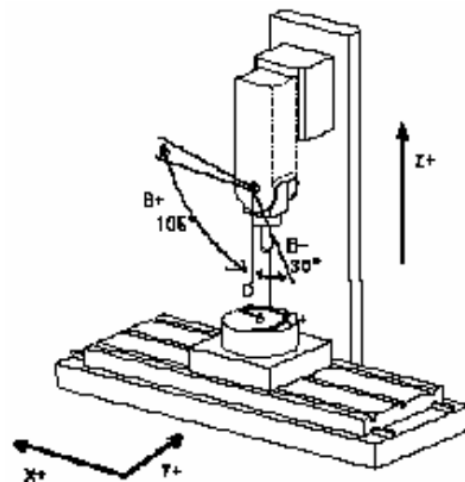

(Sketch provides good information but is difficult to read)

Axis information:

Primary Axis:

Axis of Rotation	0 Deg. Position (axis)
+ X	+ Z+ + Z- + Y+ + Y-
+ Y	+ Z+ + Z- + X+ + X-
+ Z	+ X+ + X- + Y+ + Y-

Rotation Direction (when viewed down axis of rotation plus to minus)
+ CW + CCW

Label (i.e. A, B or C): _

Secondary Axis:

Axis of Rotation	0 Deg. Position (axis)
+ X	+ Z+ + Z- + Y+ + Y-
+ Y	+ Z+ + Z- + X+ + X-
+ Z	+ X+ + X- + Y+ + Y-

Rotation Direction (when viewed down axis of rotation plus to minus)
+ CW + CCW

Label (i.e. A, B or C): _

Additional Notes

Please include any additional notes you feel we may need to process your request here: